

ATMATIC MF66/F

Fully Automatic CCD Registering Screen Printer (thin film)



RH SOLUTIONS LLC
Bringing Print to Life

4295 Armstrong Blvd, Ste 1
Batavia, OH 45103
www.RHSolutionsLLC.com
sales@rhsolutionsllc.com
ph. 513-407-5399

▣ APPLICATION :

Dedicated to process high precision screen printing onto flexible materials, such as Fine Line for FPC / PCB, BGA, Embedded Resistor for PCB, Flip Chip, Glued Frame for LCD, Touch-screen Panel, ITO conductive glass, Diffusive Plate for Backlit module, Electroluminescent, Biomedical tech test stripe, and so on. Equipped with CCD automatic registering to correct deviation of positioning while loading to raise accuracy.

▣ CHARACTERISTIC :

(1) Registering Section

Entire line consists Stacker Feeding, Registering, Printing and Offloading section, use rollers transit with robot arm vacuum suction transfer and shuttle table connecting movement of substrate. Working principle as listed below :

- ✧ Inlet via thru UPE rollers transit, adapted with centering registration structure, after then using vacuum suction with servo transit robot arm to transfer inlet loading.
- ✧ After inlet loading, substrate is located onto table top at registering section (three point edge alignment is necessary or pins registration), follow up to start table vacuum, adjustable seven section of vacuum power thru touch-screen to hold substrate firmly on table top, 4 CCD cameras shoot the target (image or hole) on substrate and feedback to the control system in compare with position. If position is deviated, XY/θ servo transmission system underneath table starts to drive table (with substrate on top) moving to precise location.
- ✧ After accomplishing registration, shuttle table starts to carry substrate to printing section and follow up to start printing right away.
- ✧ After printing, robot arm with vacuum suction enters off-loading and transfers to outlet section with UPE rollers transit.
- ✧ Printing table returns to registering section at the mean time and receives incoming substrate.

(2) Printing Section

Printing section adopts ATMA top class printing section of G7 Four -post screen printer, equipped variety unique design precise transmission and adjustment structure, smooth silent movement and accurate positioning.

- ✧ Servo printing head carriage : Linear guide rail leading (parallel precision adjustment), settable single or double squeegee (optional function) and so on 4 types of printing cycle mode, digital control setting start / end point of printing stroke, speed and equalizing of squeegee / flood coater. Also, it is possible to set manually the depth, swivel angle, skew angle of squeegee / flood coater. High class Linear cylinder is used for squeegee / flood coater up down, raises accuracy of linear exercise and stress resistance in order to present equalizing printing apparently.
- ✧ Printing table : table is made of Aluminum alloyed with precise machining, strong strength and high flatness, intensive vacuum holes ϕ 1.0mm are drilled on table top to secure substrate to get laid flatly on table top to avoid subsided by vacuum suction and uneven printing ink deposit.
- ✧ Synchronous servo peel-off : linear guide rail leading, digital control settable peel -off height, delay start. Enable to work with double squeegee cycle mode, optional function of dual servo peel -off.
- ✧ Screen micro adjustment XY/θ : precise smooth dual frame carrier design, micro adjustment knob meter to indicate adjustment volume, original coordination.
- ✧ Digital control screen up down : German SEW gear motor + double chain to drive four -post synchronous up down, digital control setting altitude (printing / stand-by / cleaning level), equipped with unique four-post locking system to secure accurate positioning.

(3) Control System

All transmission systems are digitized by assessment to reduce installation time, convenient operation to raise productivity, error and dummy proof, durable long time operation, achieve to optimize requirement for information, standardization and safety. All transmission systems are :

- ✧ 6 sets of servo motor : shuttle table right / left movement (1 set), peel-off up down (1 set), printing head forth / backward (1 set), table positioning XY/θ axis displacement (total 3 sets).
- ✧ 1 group of AC deceleration : printing section up down (German SEW gear motor + encoder).
- ✧ 2 group of digital control equalizing air pressure : 1 group for squeegee pressure, 1 group for flood

coater pressure.

- ✧ Adopt advanced PLC unit : chain locking every digital control transmission / control system mentioned above, reserve several groups of Input / output point in order to link up / downstream equipment for synchronous integration.
- ✧ Operation interface adopts switches panel + colored touch -screen : provides convenience for instant operation, setting and showing various parameters for exquisite control. Setting 100 groups memory of operation mode, only touch several icons on screen easily to get saved and retrieved memory, this is another feature of saving set up time.

(4) Safety Guard System

Equipped with other safety protection : error diagnosis loop, failure indication, single key automatic safety restoration loop, safety light barrier, emergency stop press button, warning lamp, etc. comprehensive safety protection.

(5) Automatic Registering System (CCD Visual System)

CCD Visual Registering System adopts IPC + the advanced Window version to drive three axis servo registering system for quick and precise registering. Operational interface adopts color LCD monitor + tracking ball.

1. Purpose : Use CCD optical magnification enlarges target image, analysis, contrast to achieve high resolution, capability of image resolution reaches $0.4\mu\text{m}$ to match purpose of X/Y/ servo drive and automatic precise registration. Registration accuracy is achieved $5\mu\text{m}$, fast and accurate table displacement.

2. Characteristic :

- (1) provides appropriate visual light source (extreme bright LED white light)
- (2) Field of view : FOV 10.5 x 8.4 Depth 0~6 mm.
- (3) unlimited target shape, enable to make tracking.
- (4) enable to add up to 4 CCD, increasing deviation of even accurate registration.
- (5) enable to choose edge alignment instead of CCD registering.

- (6) registration can be completed within 1 second in normal target.
- (7) operation keypad adapts waterproof anti -dust and tracking ball keypad, no need to worry other condition occurrence during use, special function key is hidden to prevent mis-touch.
- (8) adopts industrial professional screen, tempered glass, resistance acid and alkali, temperature and weather, anti-noise, long lifetime and apparent contrast.

 **SPECIFICATION :**

	DESCRIPTION	SPECIFICATION	REMARK
1	Table size (DxW, mm)	750*750m m	
2	Vacuum area (DxW, mm)	600*600m m	
3	Max. printing area	600*600m m	
4	Min. printing area	300*300m m	
5	Substrate thickness	0.1~1m m	
6	CCD capturing range	X =±125~300m m ;Y =±125~300m m	
7	CCD visual field	20*8m m	
8	Integration accuracy	±0.01m m	
9	Integration time	< 1s	
10	Max.OD frame size	1100*1100m m	
11	Min.OD frame size	900*900m m	
12	Frame height	25-45m m	
13	Screen height at cleaning level	340m m	
14	Table height	920+60m m	
15	Max.capacity	240 PH	
16	Squeegee pressure	3-63 kg	
17	Squeegee inclination	20±15°	
18	Print head speed	20-625m m /sec	
19	Printing section skew -angle	±2.5°	
20	Max. substrate size	600*600m m	
21	Min. substrate size	300*300m m	
22	Platform height	950+60m m	
23	Total stacking height	360m m	
24	Max carrying capacity	80kg	

25	Power source	3 ϕ , 220V/380V, 50/60Hz	
26	Power consumption	5kW	
27	Air pressure	5~6 kgs/cm ²	
28	Air consumption	4.5L	
29	Machine dimension	430*170*180cm	
30	Machine weight	2080kg	

3 VIEW DIAGRAM

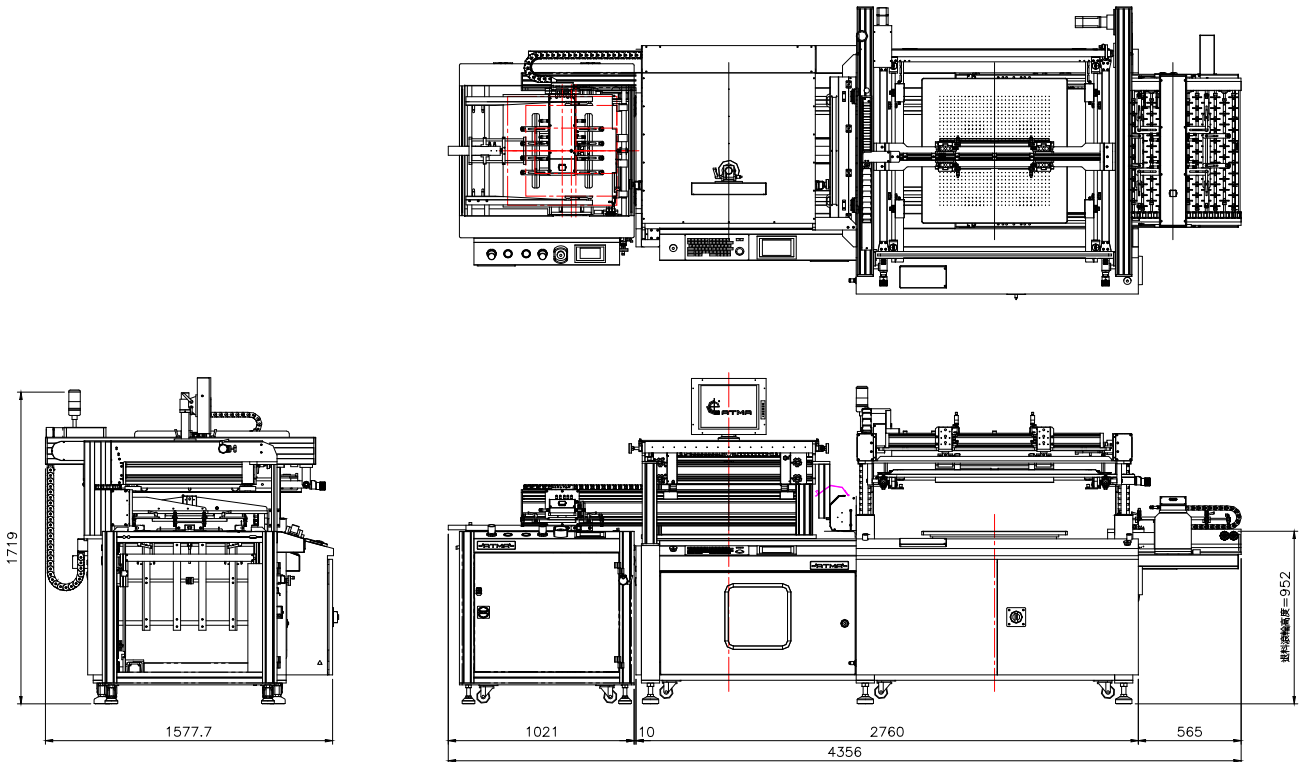

RH SOLUTIONS LLC
Bringing Print to Life

4295 Armstrong Blvd, Ste 1
Batavia, OH 45103
www.RHSolutionsLLC.com
sales@rhsolutionsllc.com
ph. 513-407-5399